



**TELESCOPIC FORKLIFT** | T 30 D

## EFFICIENCY AND COST OF OWNERSHIP

THE T 30D TELESCOPIC FORKLIFT DOES EVERYTHING A MASTED FORKLIFT DOES... AND MORE.

REDUCING COST OF OWNERSHIP, SAVES YOU TIME, FUEL, MANPOWER AND YARD LOADING SPACE. ADD TELESCOPIC FORKLIFT POTENTIAL TO REPLACE SEVERAL MACHINES, WHICH MEANS YOU DON'T NEED AS MANY MASTED FORKLIFTS IN YOUR FLEET, AND THE RESULT IS MAXIMUM EFFICIENCY AND PRODUCTIVITY.



Reliable quality with a huge fuel saving. The FORKLIFT Standard Engine we have equipped.



Designed specifically for forklift, The Xinchai brand diesel engine is the Chinese forklift main supplier. It adopts a number of advanced diesel engine design techniques and manufacturing processes independently developed by the company. It is highly praised by forklift users. Reliable quality, easy to start in winter, with fuel-saving technologies, Compact structure and easy maintenance. And can meet the requirements of European III emission regulations.

 **XINCHAI 36KW**



Yanmar Novel CAE technologies were used to obtain the best muffler volumes and sound-proofing materials. has made T 30D forklift noise more lower. Indirect Injection engine, clean exhaust. Can meet the requirements of European III & EPA III emission regulations.

 **YANMAR 42KW**

**YANMAR 4TNE98 in option.**

## OPERATIONAL EFFICIENCY

Thanks to the telescopic boom T30D, you can load and unload a lorry trailer from only one side. This results in up to 50% yard loading space saving; you can use the rest of the loading space for other duties and there is also no need to spend extra time repositioning vehicles around work yards.

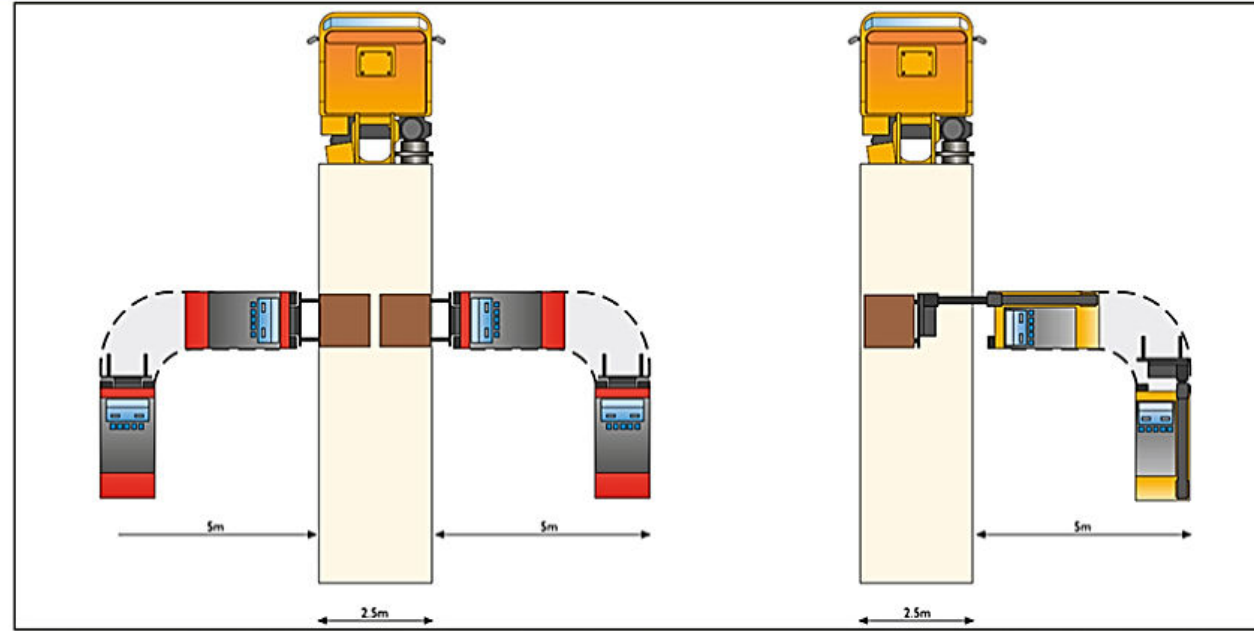

## Crossing obstacles to take the goods



# SPECIFICATION T30D TELESCOPIC FORKLIFT

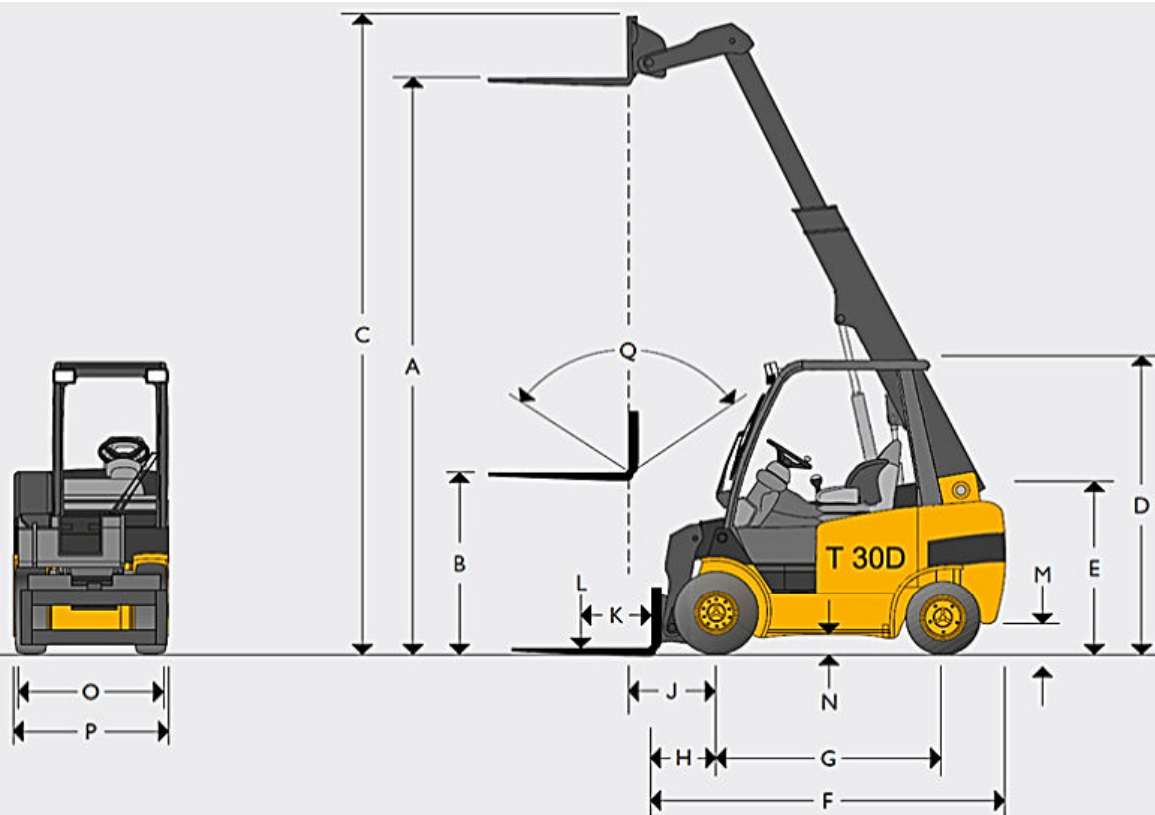

Model	T 30D	T 30D
Engine Manufacturer	XINCHAI / XINCHAI 498	YANMAR
Tier compliant	NA/EU III	EPA III & EU III
Engine model	C490BPG / A 498 BPG1	4TNE98
Engine output (gross power) kw	36.8	42.1
Cubic capacity cm <sup>3</sup>	2670 / 3168	3319
Rated rpm	2600	2600
Number of cylinders	4	4
Working pressure bar	190	190
Maximum reach boom horizontal (500mm load centre) mm	2380	2380
Turning radius mm	2500	2500
Weight unladen kgs	4900	4900
Travel speed km/h	20	20
Gradeability (laden / unladen) %	25 / 21	25 / 21
Transmission	Electro-hydraulic automatic	Electro-hydraulic automatic
Park brake type	Hand	Hand
Tyres (Front)	28x9-15	28x9-15
Tyres (Rear)	6.50-10	6.50-10
Diesel tank capacity L	56	56

A	Lift height	mm	4060
B	Free lift	mm	1400
C	Height (Boom extended).	mm	4680
D	Height of overhead guard	mm	2300
E	Height of operators seat (high/low)	mm	1200 / 1150
F	Length to fork face	mm	2850
G	Wheelbase	mm	1680
H	Distance from c/l of front axle to fork face	mm	600

J	Distance from c/l of front axle to fork face (full height)	mm	850
K	Load centre	mm	500
L	Lift capacities (with side shifter)	kg	3000
M	Ground clearance (lowest point)	mm	200
N	Ground clearance (wheelbase centre)	mm	190
O	Fork carriage width	mm	1280
P	Maximum width of machine	mm	1400
Q	Carriage tilt total* F/B variable through lift arc	degrees	111

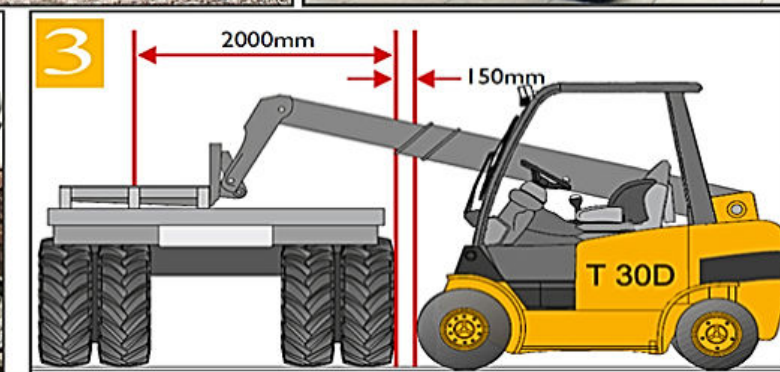

# Forward reach

- 1** Telescopic forklift T 30D attachments, plus compatibility with the full range of industry specific attachments, gives you huge flexibility and the ability to work in a wide range of applications.
- 2** 111 degrees of carriage rotation makes handing of unpalletised goods much easier and safer. Access all areas.
- 3** The telescopic boom allows single-side loading, loading to the far side of rail wagons by reaching across the platform gap, reaching inside sprinter vans and loading of ships by reaching across from the quayside.

# T30D MAKE EVERYTHING EASY

## 1 Fully tilting cab.

Ground-level access to all the major components and service interval checks is quick and easy through the side-opening door and tilting cab.

The operators daily checks are behind the side door.



## 2 Diesel tank

The diesel tank is also within easy reach, and there's an unobstructed view of the indicator.

## 3 Gauge board

Succinct and gener gauge board make you easy read.

## 4 Joy stick

T30D has made all function in one joy stick, even the drive.

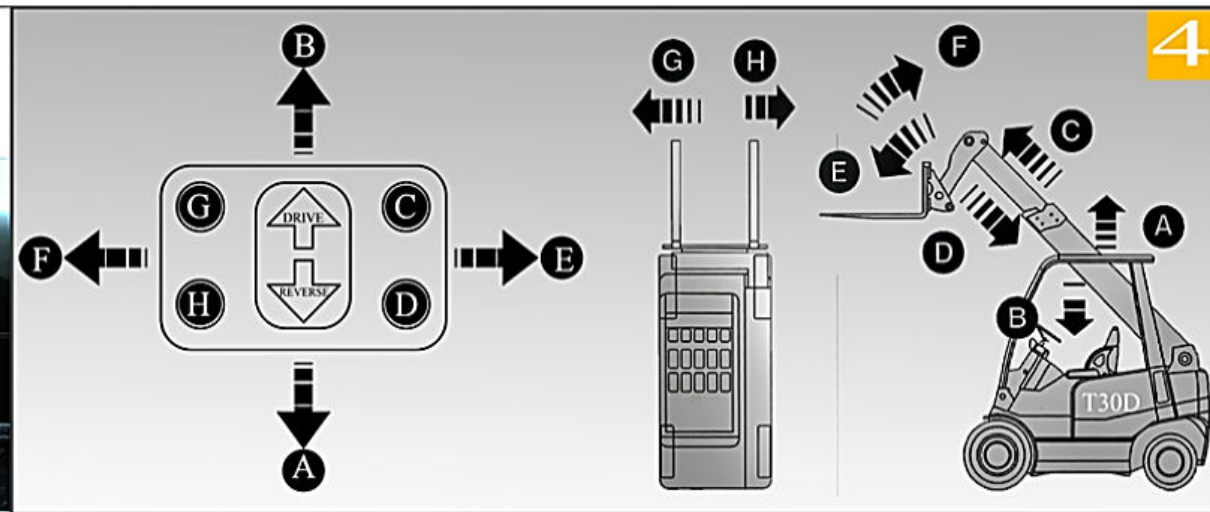



Front FOPS

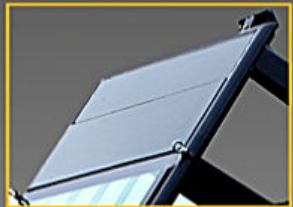

12 mm Top FOPS



Big and Non-slip Brake pedal



Solid tires in option



All LED Light equip in truck



Fully adjustable suspension seat



Lifting and transporting hole

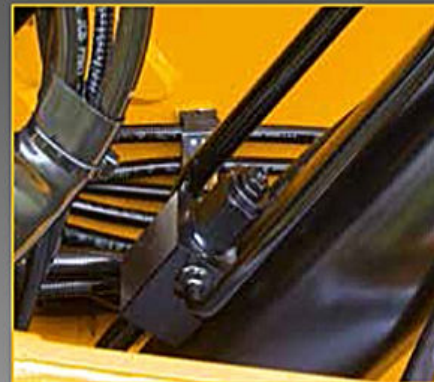

Boom and oil cylinder  
 Hose burst check valve  
 Self leveling pallet fork  
 111 degrees carriage rotation  
 Power lift lower extend and retract  
 for complete control

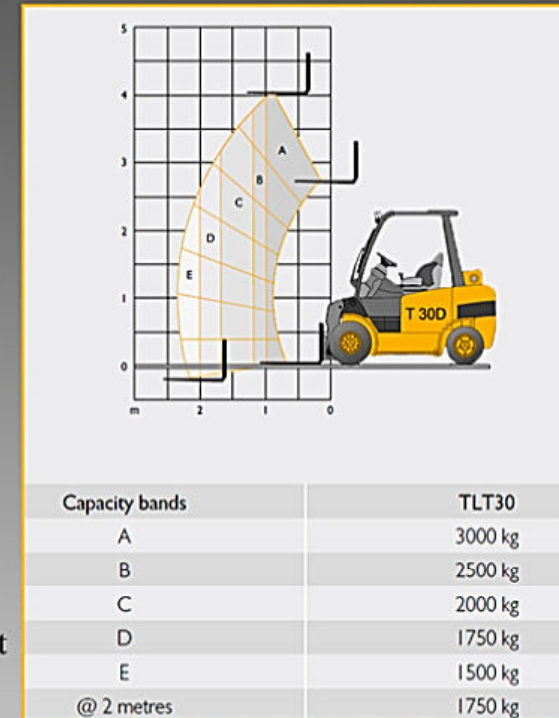

3 TONS TO 20 TONS ROUGH TERRAIN FORKLIFT